

Horizontal wrapping machine **CL 010 - 400 / 600 / 800**



A basic machine for
universal application



Holding. Wrapping. Packaging.



Machine description

The **CL 010** was designed according to our sophisticated, well-established solutions for your applications, which have proven their worth in the market, and is **fully CE compliant**. It is a **manually** operated **Circle Line wrapping machine** for universal application for **long goods, stack packaging, tray packaging, cardboard boxes** and **sheet formats**.

The work table with **PVC-coated rollers** can be adapted to fit the task, depending on its purpose and the product. The wrapping head can be installed **at three different heights**, depending on the requirements. This ensures a **simple and safe handling and wrapping process** for small and short products.

The **continuously adjustable braking roller** ensures **an even film tension**, thereby guaranteeing the machine's **high wrapping quality**.

Simple parameter input on a control unit complements the machine's equipment. Our **special machine design** allows for **risk-free operation** directly in the wrapping area of this modern, reliable wrapping machine.

Application:

The products are **manually pushed** into the wrapping area via the working surface of the machine. The operator grips the film and **uses the foot pedal** switch to start the wrapping ring drive. After the second revolution, the start of the film is **fastened in place** and the bundling or wrapping process can be continued.

If the foot pedal switch is released, the **wrapping ring stops at the position** in which the film can be **freely gripped and torn off**. The film tail is pressed to the product by hand.

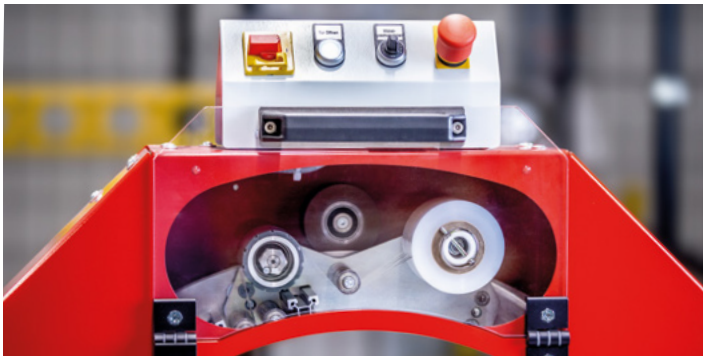

Equipment features

The basic machine can be equipped with a film accommodation mandrel with a diameter of 38 mm.

Design options

You decide which special RAL colours to use for the machine supplied by.

All machines from Wrapsolut can be used inline. More info under www.wrapsolut.de



Accessories

✓ Second film roll intake

The wrapping ring is equipped with a second film intake. The film rolls are positioned so that they are opposite each other. This doubles the processing speed. In addition, the arrangement of film rolls on opposite sides ensures mutual compensation of the film tension on the product. This facilitates product handling during the wrapping process. Another advantage is that the machine can be equipped with twice the amount of film.



Technical data for CL 010 - 400 to 800

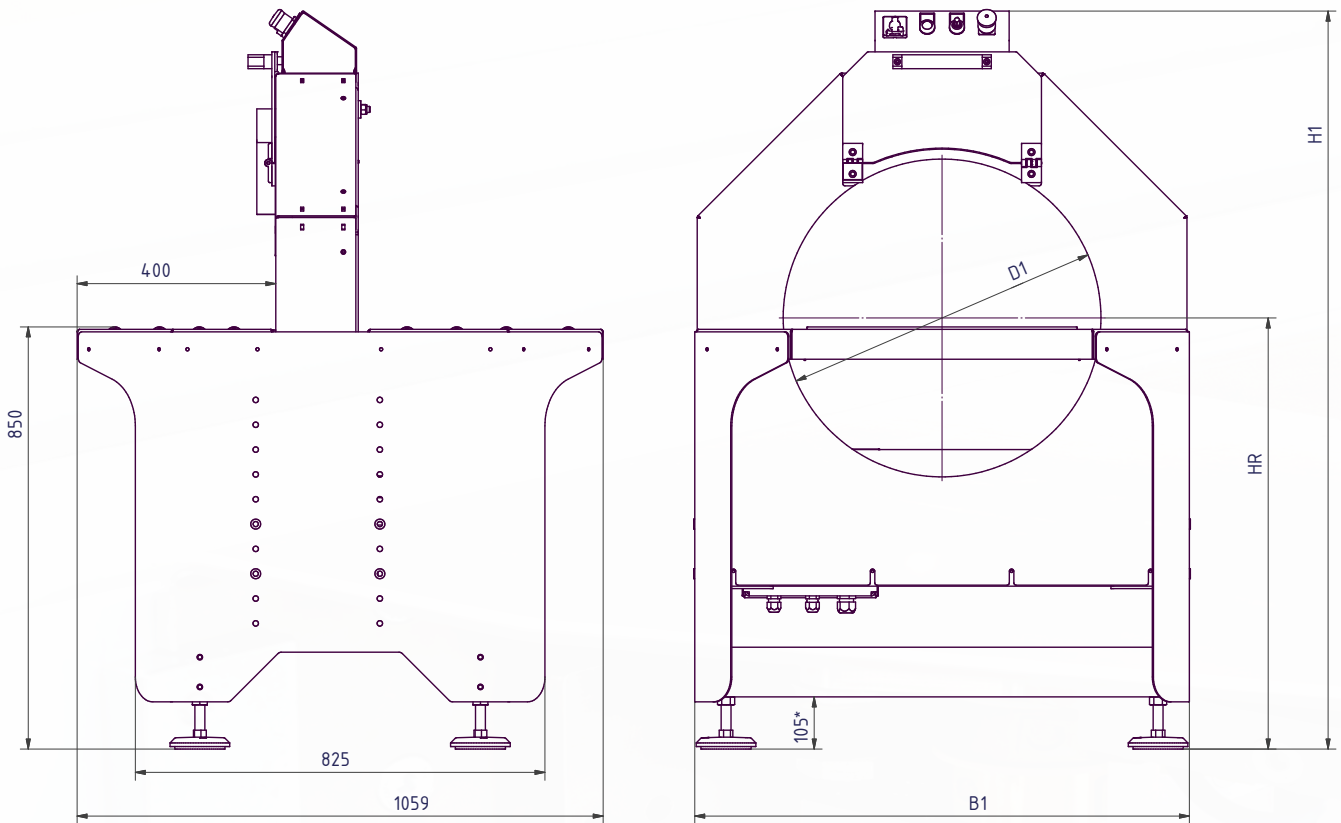

* adjustable between 75 mm und 145 mm
Dimensions in mm
Technical changes reserved

machine size	D1	B1	HR**	H1**	** adaptable to
CL 010 - 400	440	800	863	1381	+50 / +100
CL 010 - 600	640	1000	868	1486	+50 / +100 / +150
CL 010 - 800	840	1200	868	1584	+50 / +100 / +150 / +200

- Operating unit for:
– ring speed
- Safety closing mechanism of the film change flap

Product cross section (mm)	400 / 600 / 800 (maximum)
Wrapping ring speed	2.9 / 2.2 / 1.7 (per second, maximum)
Film width	80 mm (maximum)
Film roll exterior Ø	120 mm (maximum)
Roll core / film accommodation mandrel	available in Ø 38 mm (1.5")
Electrical connection	Mains voltage 230V+N+PE Power plug 16A / Schuko Control voltage 24 VDC

✓ Tongue in wrapping area

The tongue in the wrapping area is an aid for supporting flexible and/or short products during transfer from the infeed to the outfeed conveyor and holding them in place even more securely during the wrapping process.

✓ Manual lateral guide

This unit consists of a pair of lateral guide rollers, which can width-adjusted.

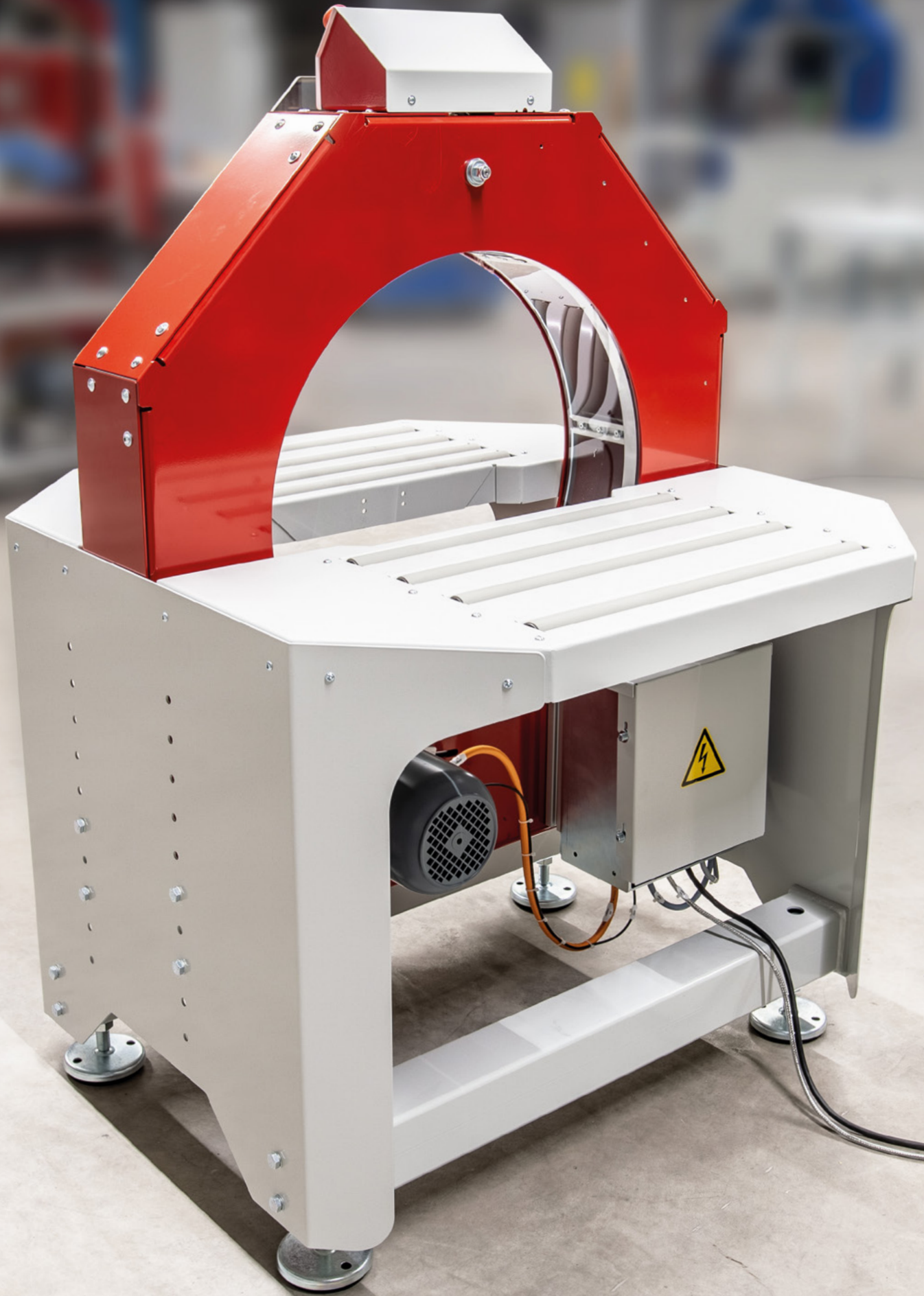



Our customised solutions for your industry through:

- ✓ technical consultation and project support
- ✓ machine development (mechanical and electrical)
- ✓ PLC control development and programming
- ✓ machine production and assembly
- ✓ delivery, commissioning and instruction
- ✓ reliable and quick service and delivery of spare parts

All machines from Wrapsolut can be used inline. More info under www.wrapsolut.de

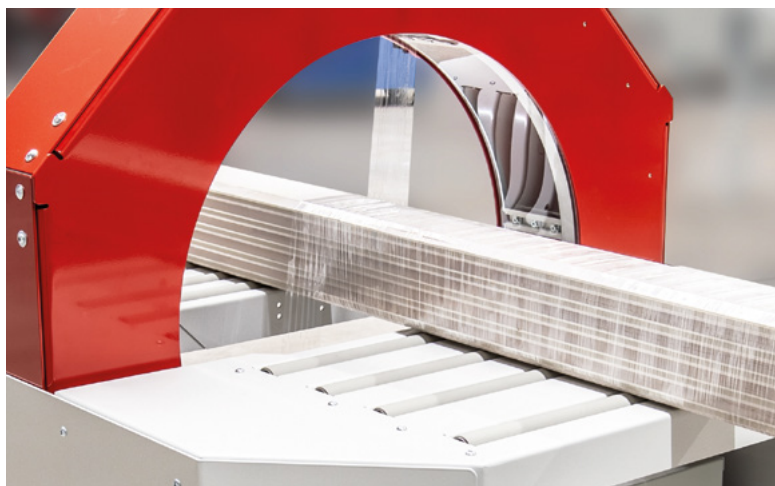
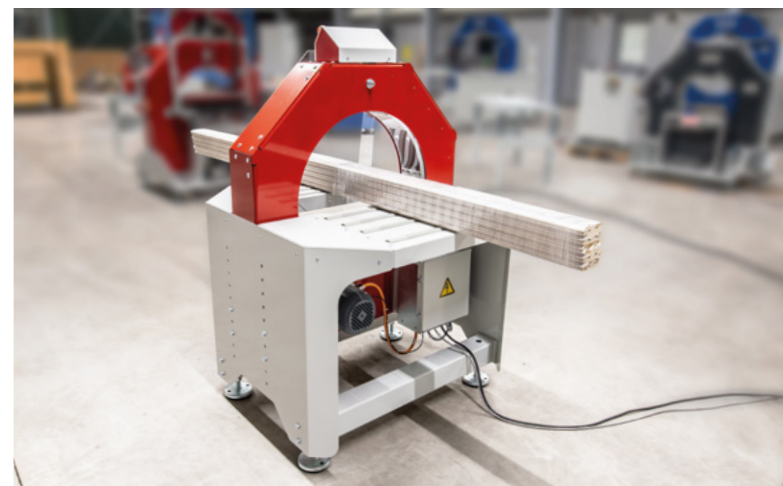

Fährenkämper GmbH & Co. KG

Kampstraße 35
D-32584 Löhne

Fon: + 49 (0) 57 31 / 8 60 01-0
Fax: + 49 (0) 57 31 / 8 60 01-11

E-Mail: info@faeco.de
Internet: www.wrapsolut.de